

TYPICAL ROADWAY AND DITCH SECTION

CADE SUBDIVISION

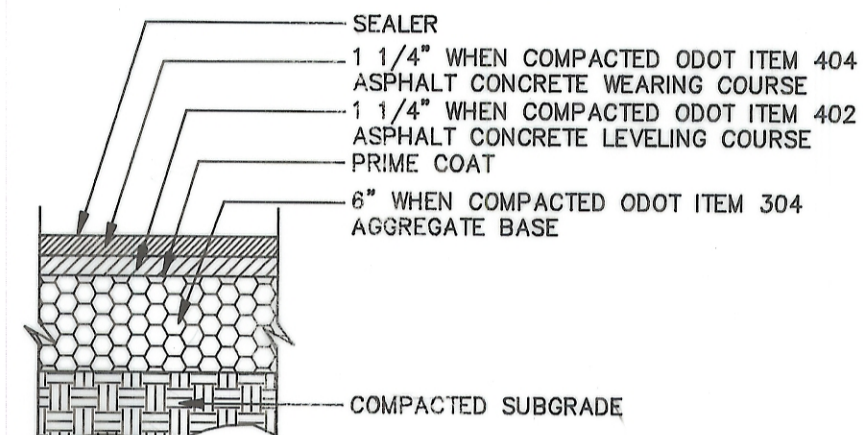

ASPHALT PAVEMENT: STREET

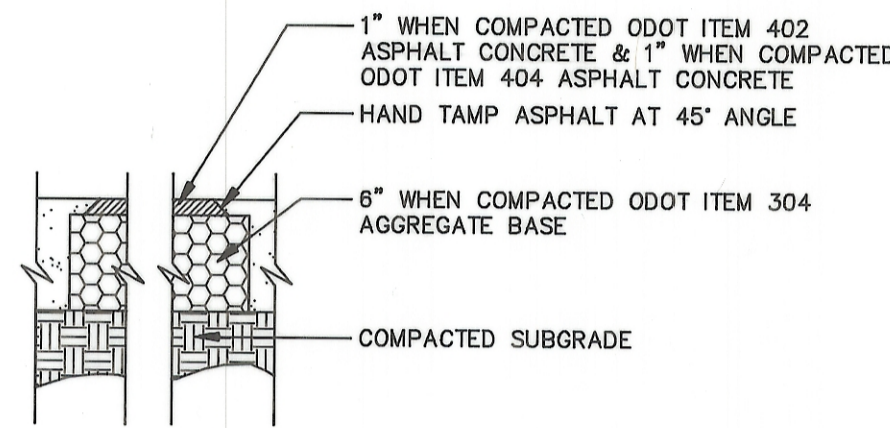

ASPHALT PAVEMENT: DRIVEWAYS

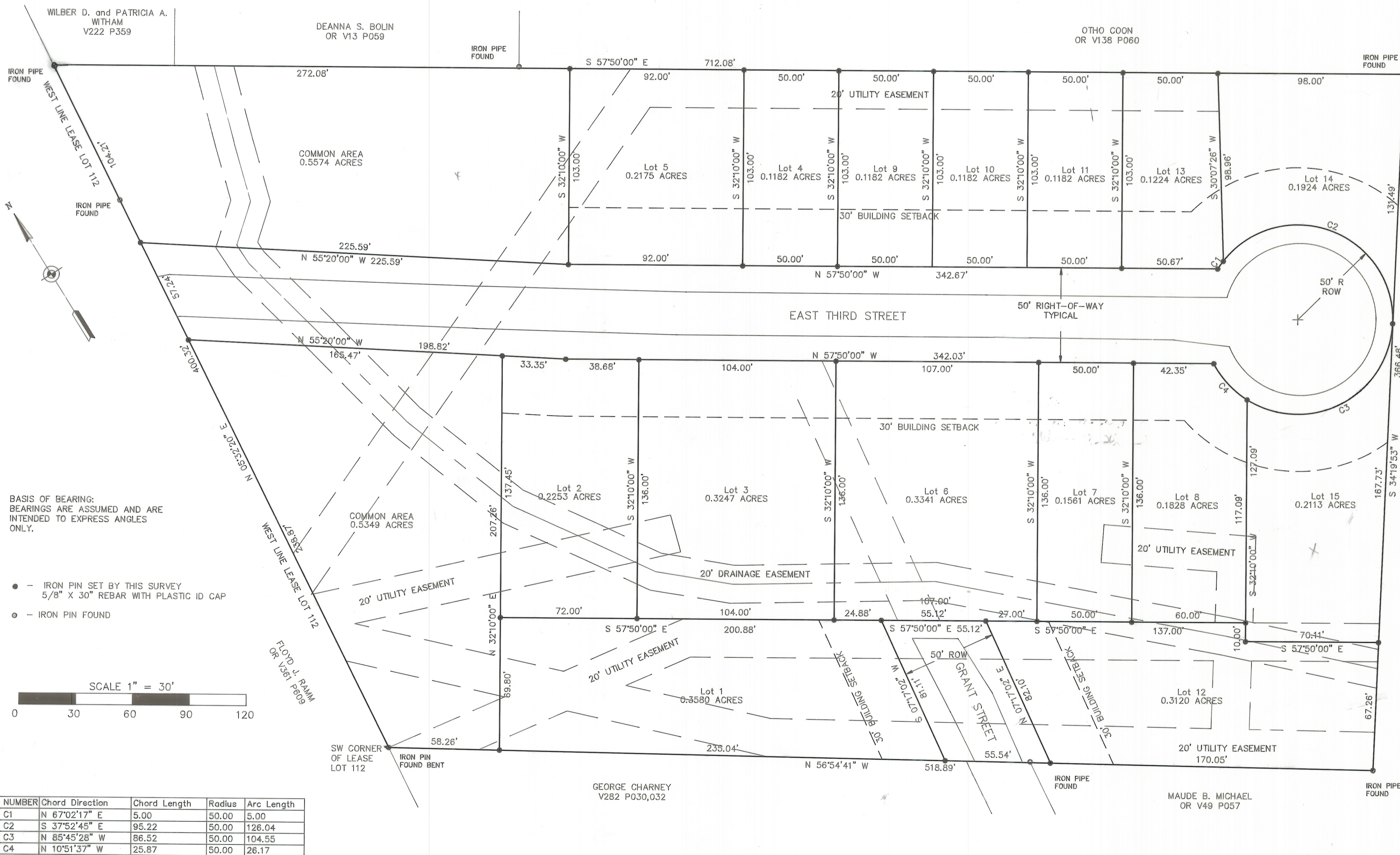

BASIS OF BEARING:
BEARINGS ARE ASSUMED AND ARE
INTENDED TO EXPRESS ANGLES
ONLY.

- - IRON PIN SET BY THIS SURVEY
5/8" X 30" REBAR WITH PLASTIC ID CAP
- - IRON PIN FOUND

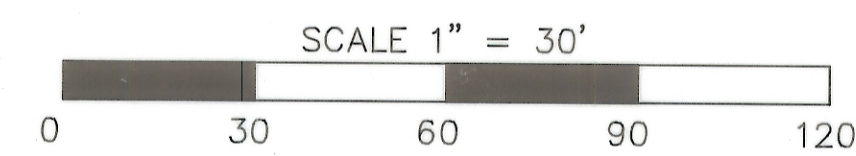

NUMBER	Chord Direction	Chord Length	Radius	Arc Length
C1	N 67°02'17" E	5.00	50.00	5.00
C2	S 37°52'45" E	95.22	50.00	126.04
C3	N 85°45'28" W	86.52	50.00	104.55
C4	N 10°51'37" W	25.87	50.00	26.17

Situated in Section 24, Athens Township, Town 10, Range 14, of the Ohio Company Purchase, Athens County, Ohio and containing 5.107 acres and being a tract of land conveyed to Athens Metropolitan Housing Authority and described by deed of record in Deed Book 372, Volume 069, Athens County, Ohio.

The undersigned Athens Metropolitan Housing Authority hereby certify that the attached plat correctly represents their Cade Subdivision, a subdivision of lots 1 to 15 inclusive, do hereby accept this plat of same and dedicate to public use as such all or parts of the roads, boulevards, cul-de-sacs, parks, planting strips, etc., shown herein and not heretofore dedicated.

The undersigned further agrees that any use of improvements made on this land shall be in conformity with all existing valid zoning, platting, health or other lawful rules and regulations including the applicable off-street parking and loading requirements of Athens County, Ohio, for the benefit of himself and all other subsequent owners or assigns taking title from, under or through the undersigned.

In witness thereof Thad S. Dye, Executive Director, Athens Metropolitan Housing Authority has hereunto set his hand this 1st day of Aug, 1996.

Witness Amy J. Hill Secretary
Thad S. Dye Executive Director

I do hereby certify that I have surveyed the premises and prepared the attached plat and that said plat is correct.

By Eugene Triplett Eugene Triplett (PS 6766)

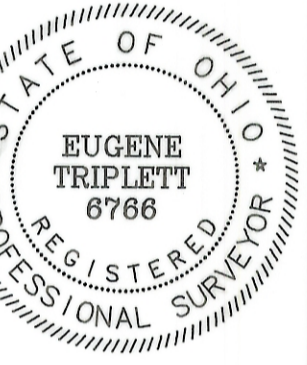

STATE OF OHIO
COUNTY OF ATHENS

Before me a Notary Public in and for said County personally came Thad Dye who acknowledged the signing of the foregoing instrument to be their voluntary act and deed for the uses and purposes therein expressed.

In witness whereof I have hereunto set my hand and affixed my official seal this 1st day of August, 1996.

By Sharon Rhoads
Notary Public
Sharon Rhoads

Approved this 1st day of August, 1996.

Margaret F. Cohen (City Planning Commission)
Acting Chair

Approved this 24 day of August, 1996.

Ray C. Phillips (President, City Council)

Approved this 5 day of August, 1996.

Wayne C. Key (City Service-Safety Director)

Reviewed this 14 day of September, 1996.

Madeline Wilson (Athens Township Trustees)

Ralph Nazam

William R. Shaw

Approved this 3rd day of October, 1996.

John H. Haly (County Engineer)

Approved this 22 day of October, 1996.

Joe Kasler, R.S. (County Board of Health)

Approved this ___ day of ___, 1996.

(County Regional Planning Commission)

(Approval of this plat for recording does not constitute an acceptance of the dedication of any public street, road, or highway dedicated on such plat, Section 711.04 and 711.041, Ohio Revised Code.)

Barbara Swain (Athens County Commissioners)

William H. (Bill) Shiver

Transferred this 18th day of October, 1996 at

David S. Rowett (Athens County Auditor)

Filed for record this 23 day of October, 1996, in Plat-book 471-B,
Page No. ___ File No. ___

Julia Michael Scott (Athens County Recorder)

Jessie Brandt Markins (Athens County Deputy Recorder)

960007836
Filed for Record in
ATHENS COUNTY, OHIO
JULIA MICHAEL SCOTT
On 10-23-1996 At 09:53 aa.
PLAT 43.20
ENJ 471-B