

# SOUTHEASTERN LAND SURVEYS

LEONARD F. SWOYER  
REGISTERED PROFESSIONAL LAND SURVEYOR

3428 Pleasant Hill Road  
Athens, Ohio 45701  
614/593-8701

Situated in Fraction 3, Section 9, Town 6, Range 12, Rome Township, Athens County, Ohio and described as follows:

Commencing at the southeast corner of Section 9; thence on an assumed bearing North 00 degrees 00 minutes 00 seconds East, a distance of 165.00 feet to a point; thence North 90 degrees 00 minutes 00 seconds East, a distance of 2179.24 feet to a point at the southwest corner of a 1.01 acre tract described in Volume 310 Page 459 of the Athens County Deed Records; thence North 00 degrees 00 minutes 00 seconds East along the west line of said 1.01 acre tract, passing a found iron pin at 283.95 feet, for a total distance of 318.95 feet to a point at the northwest corner of said 1.01 acre tract in State Route 144; thence along State Route 144 the following two bearings and distances: 1) North 72 degrees 27 minutes 42 seconds West, a distance of 261.66 feet to a point; thence 2) North 80 degrees 12 minutes 10 seconds West, a distance of 549.29 feet to a point, THE TRUE POINT OF BEGINNING; thence leaving said road along an arbitrary line the following five bearings and distances: 1) South 11 degrees 00 minutes 00 seconds West, passing a set iron pin at 32.57 feet, for a total distance of 312.75 feet to a set iron pin; thence 2) South 13 degrees 31 minutes 33 seconds West, a distance of 232.48 feet to a set iron pin; thence 3) South 86 degrees 20 minutes 04 seconds West, a distance of 487.07 feet to a set iron pin; thence 4) South 60 degrees 10 minutes 22 seconds West, a distance of 982.70 feet to a set iron pin; thence 5) North 3 degrees 01 minute 28 seconds West, passing a set iron pin at 585.71 feet, for a total distance of 605.00 feet to a point in aforesaid State Route 144; thence along said road the following two bearings and distances: 1) North 70 degrees 11 minutes 42 seconds East, a distance of 50.00 feet to a point; thence 2) North 75 degrees 35 minutes 09 seconds East, a distance of 174.13 feet to a point at the intersection of said State Route 144 with an existing culvert at the southeast corner of a 3.37 acre tract described in Volume 135 Page 169 of the Athens County Official Deed Records; thence along the east line of said 3.37 acre tract North 0 degrees 54 minutes 51 seconds West, a distance of 234.47 feet to a point in the center of the Hocking River; thence along the center of said Hocking River the following two bearings and distances: 1) North 62 degrees 55 minutes 16 seconds East, a distance of 351.47 feet to a point; thence 2) North 47 degrees 19 minutes 45 seconds East, a distance of 682.35 feet to a point in Rome Township Road 189; thence along said Rome Township Road 189 South 16 degrees 31 minutes 03 seconds East, a distance of 305.93 feet to a point at the intersection of said Rome Township Road 189 with aforesaid State Route 144; thence along said State Route 144 the following four bearings and distances: 1) North 85 degrees 41 minutes 14 seconds East, a distance of 35.27 feet to a point; thence 2) South 68 degrees 59 minutes 10 seconds East, a distance of 69.80 feet to a point; thence 3) South 59 degrees 15 minutes 50 seconds East, a distance of 222.82 feet to a point; thence 4) South 63 degrees 51 minutes 05 seconds East, a distance of 88.16 feet to the POINT OF BEGINNING and containing 24.879 acres, and being a part of a 168.63 acre tract described in Volume 301 Page 131 of the Athens County Deed Records.

Note: Unless otherwise noted, all set iron pins are 5/8 inch diameter rebar and 30 inches in length and capped with a plastic identification marker inscribed L.F. Swoyer R.L.S. 6765.

The above description was prepared under the supervision of Leonard F. Swoyer Registered Professional Land Surveyor No. 6765 and based on a survey performed by Southeastern Land Surveys dated September 23, 1997.

Subject to all easements and right of ways of record.

Description checked for  
Instrumental Accuracy  
ATHENS COUNTY  
ENGINEERS OFFICE  
BY: *Donna McLean*  
DATE: *10-1-97*

222

Rom #9

PROPERTY

CONSTRUCTION

SUBDIVISIONS

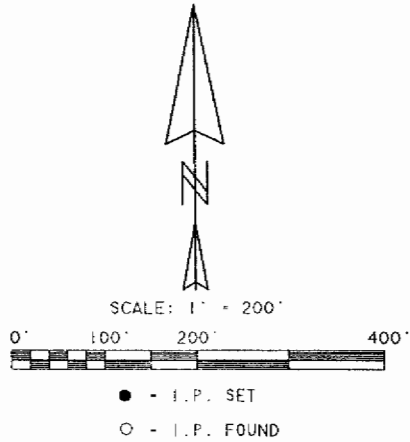

LINE	BEARING	DISTANCE
L 1	N 70° 11' 42" E	50.00'
L 2	N 85° 41' 14" E	35.27'
L 3	S 68° 59' 10" E	69.80'
L 4	S 63° 51' 05" E	88.16'

CHARLES E. &  
CANDACE J.  
BYRON  
89-665 O.R.  
39.50 AC.

DESSIE M. WORKMAN  
135-169 O.R.  
3.37 AC.

24.879 AC.

WILMA L. MINEAR  
301-131  
168.63 AC.

D. J. & R. W. WELL  
275-83  
109.28 AC.

J. A. BUTCHER  
310-459  
1.01 AC.

HOCKING RIVER

STATE RT. 144

STATE RT. 144

\* PLAT OF SURVEY OF A 24.879 ACRE TRACT \*  
SITUATED IN FRACTION 3, SECTION 9, TOWN 6, RANGE 12,  
ROME TOWNSHIP, ATHENS COUNTY, OHIO  
\* PREPARED BY: SOUTHEASTERN LAND SURVEYS  
SEPTEMBER 23, 1997 FOR: CARL LOCKHART

*Leonard F. Swoyer*  
LEONARD F. SWOYER P.S. 6765

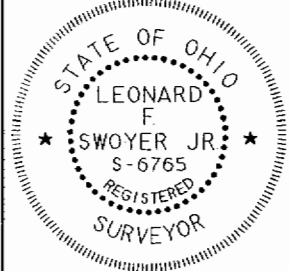

Description checked for  
Mathematical Accuracy  
ATHENS COUNTY  
ENGINEER'S OFFICE  
BY: *Donna McLean*  
DATE: *10-1-97*

223

224