

HIGHLAND SURVEYING LTD.

80 Fayette St.
Nelsonville, Ohio 45764

Phone 740-753-1264
Fax 740-753-1264

Legal Description Pre-Approval
APPROVED
All transfers are subject to
Athens County Conveyance Standards

SEP 06 2023

Description of a 0.996 Acre Tract

Jill Davidson
Athens County Auditor

Situated in Section 7, T-12, R-15, York Township, Athens County, State of Ohio and being part of a tract described Official Records Volume 304, Page 1646 and being more particularly described as follows:

Commencing at a point in the center of TR-268 which is the Southeast corner of a 2.00 acre tract (Breeze, et al 529-2490 OR), that bears North $71^{\circ}10'40''$ West, 2377.16 feet from the Southeast corner of Section 7, thence along the South line of said tract North $84^{\circ}10'05''$ West, 90.00 feet to an iron pin found at the POINT of BEGINNING of this tract,

THENCE along four new lines with the following courses and distances:

- 1) South $67^{\circ}04'55''$ West, 197.39 feet to an iron pin set,
- 2) South $44^{\circ}46'50''$ West, 104.22 feet to an iron pin set,
- 3) North $87^{\circ}23'29''$ West, 187.05 feet to an iron pin set,
- 4) North $29^{\circ}18'22''$ East, 203.34 feet to an iron pin set,

THENCE along the line of Breeze, et al (529-2490 OR), South $84^{\circ}10'05''$ East, 344.33 feet to the point of beginning, (passing an iron pin found at 19.90 feet), and containing 0.996 acres.

This tract must remain continuous and contiguous with the 2.00 acre tract to the North

Survey completed and Description written in August 2023

All Iron Pins set are $5/8$ "x30" rebar with ID Caps labeled "HIGHLAND S 7581"

Bearings are to an assumed meridian and are for angular determination only

Subject to all Easements and Rights of Way of Record

Kenneth E. Highland S-7581



Description Checked for
Mathematical Accuracy
Athens County
ENGINEER'S OFFICE

BY: *Brian W. Miller*
DATE: 8/30/23

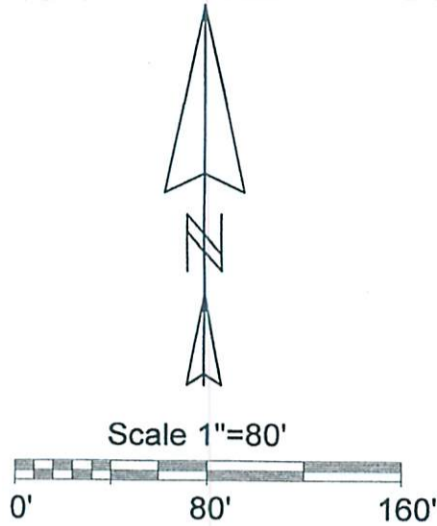

Line	Bearing	Distance
12	S 67°04'55"W	18.18'
13	N 84°10'05"W	38.85'
14	S 69°46'58"W	71.96'
15	S 57°52'35"W	55.60'
16	S 47°45'58"W	81.12'
17	S 44°23'48"W	53.56'

Breeze, etal
529-2490 OR
2.00 Ac.

TR-268

Breeze
304-1646 OR

0.996 Ac.

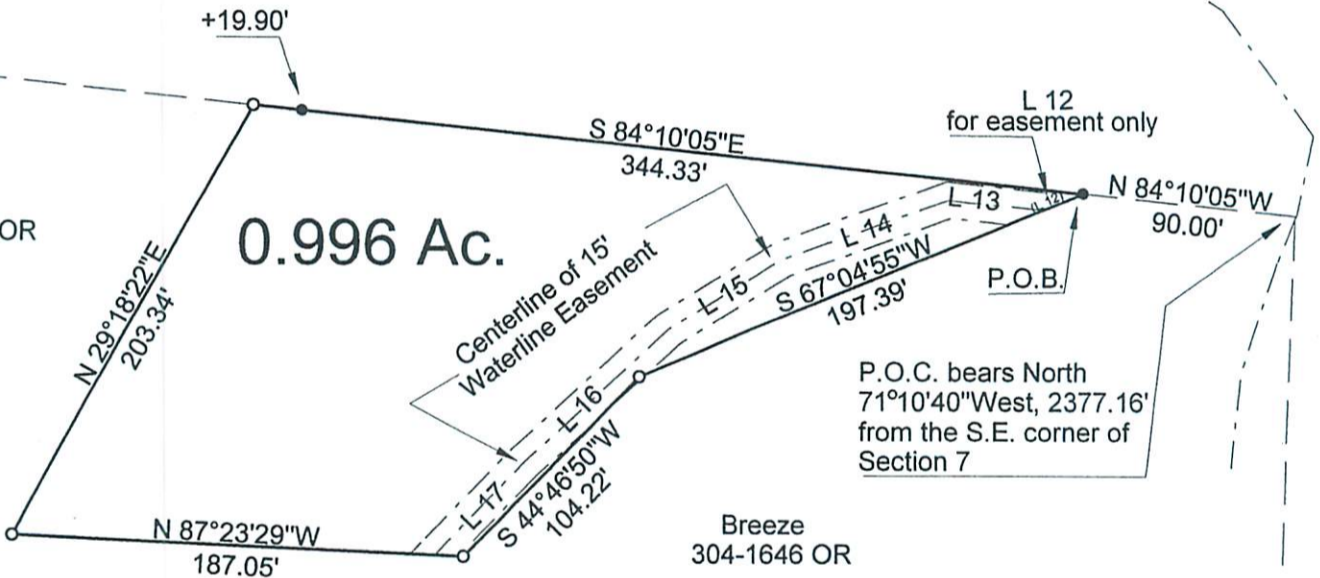

NOTE:
This 0.996 acre tract
must remain continuous
and contiguous with the
2.00 acre tract to the
north

Surveyed in Aug. 2023

○ = Iron Pin Set
5/8"x30" rebar
w/ plastic ID Cap

● = Iron Pin Found

REFERENCES
Tax Plats
Surveys
Deeds

BASIS of BEARING
Assumed

Description Checked for
Mathematical Accuracy
Athens County
ENGINEER'S OFFICE

BY: *Bryan W. Williams*
DATE: 8/30/23

PLAT OF SURVEY OF A 0.996 Ac. TRACT & EASEMENT

SURVEYED FOR BREEZE

SUBDIVISION —

TOWNSHIP YORK SECTION 7 TOWN 12 RANGE 15

CORPORATION — COUNTY ATHENS STATE OHIO

SCALE 1"= 80' DATE AUG, 2023

Kenneth E. Highland
80 Fayette St.
Nelsonville, Ohio 45764
740-753-1264



Kenneth E. Highland S-7581