

Phone 740-753-1264
Fax 740-753-1264

Description of a 0.057 Acre Tract

Situate in the City of Athens, County of Athens, And State of Ohio and being a part of Lot 3221 of the West Hill Estates Subdivision and being more particularly described as follows:

Commencing at the Northeast corner of Lot 3220 of said subdivision,

THENCE North 90°00'00"East, 50.00 feet to the POINT OF BEGINNING of this tract,

THENCE North 0°27'00"West, 50.00 feet to the Southwest corner of a 0.18 acre tract (353-407),

THENCE along the south line of said tract and the North line of Lot 3221 South 90°00'00"East, 50.00 feet to a point at the Northeast corner of said lot,

THENCE along the east line of said lot South 0°27'00"East, 50.00 feet to a point,

THENCE North 90°00'00"West, 50.00 feet to the point of beginning and containing 0.057 acres.

Bearings are to an assumed meridian and are for angular determination only

Subject to all Easements and Rights of Way of record



Description checked for
Mathematical Accuracy
ATHENS COUNTY
ENGINEER'S OFFICE
BY: S. Blause
DATE: 6-13-00

000105

Second St.

N 90°00'00"E

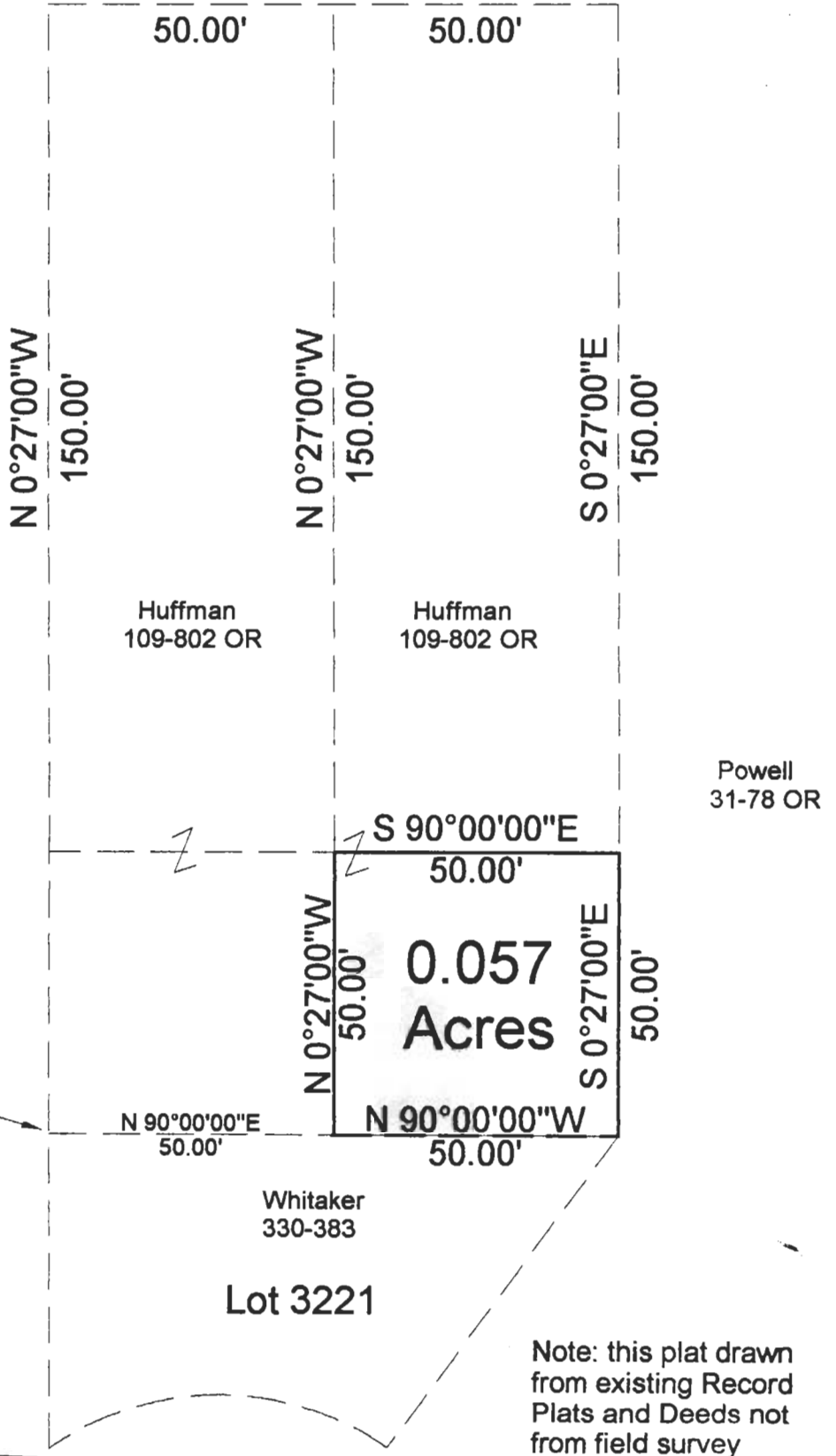
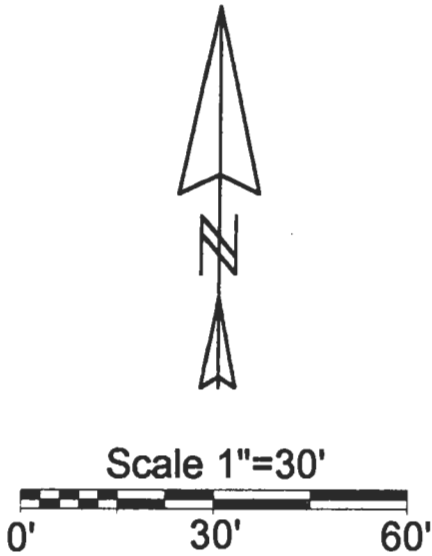

Description checked for
Mathematical Accuracy
ATHENS COUNTY
ENGINEER'S OFFICE
BY: S. Blause
DATE: 6-13-00

Note: this plat drawn
from existing Record
Plats and Deeds not
from field survey

PLAT OF DESCRIPTION OF A 0.057 AC. TRACT

SURVEYED FOR _____

SUBDIVISION WEST HILL ESTATES

TOWNSHIP ATHENS SECTION _____ TOWN _____ RANGE _____

CORPORATION ATHENS COUNTY ATHENS STATE OHIO

SCALE 1"= 30' DATE JUNE 2000

Kenneth E. Highland
80 Fayette St.
Nelsonville, Ohio 45764
740-753-1264



Kenneth E. Highland S-7581

000107

ATH City 76