



C. Thomas Smith

Ohio Professional Surveyor No. 6844

P.O. Box 393

Racine, Ohio 45771

740-949-2524

Exhibit D

Description of survey for Matt Collins
Tract 5

Being a part of an 46.408 acre tract of land transferred to Gail and Rebecca Wemer as recorded in Official Records Volume 307 at page 1907 Athens County Recorder's Office, Athens County, Ohio, also being a part of Section 5, Township-10, Range-14, Dover Township, Athens County, State of Ohio and more particularly described as follows;

Beginning at a 5/8" iron pin set on the grantor's south property line also being the north property line of a tract transferred to Riley and Evelyn Russell as recorded in Official Records Volume 216 at page 706 and bears South 90°00'00" West a distance of 500.00 feet from an existing iron pin being the southeast corner of the Northeast Quarter of Section 5, T-10, R-14;

Thence along the north line of said Russell tract South 90°00'00" West passing thru a 5/8" iron pin set at a distance of 857.72 feet and going a total distance of 887.72 feet to a point in the centerline of Township Road 333, S. Wemer Road;

Thence leaving said north line and along said centerline the following nine courses;

1. North 33°29'41" West a distance of 55.24 feet to a point;
2. North 21°00'17" West a distance of 77.30 feet to a point;
3. North 09°38'49" West a distance of 138.62 feet to a point;
4. North 03°03'56" West a distance of 87.07 feet to a point;
5. North 04°13'21" East a distance of 67.92 feet to a point;
6. North 20°29'20" East a distance of 41.23 feet to a point;
7. North 40°55'04" East a distance of 40.80 feet to a point;
8. North 47°33'27" East a distance of 57.92 feet to a point;
9. North 34°08'12" East a distance of 84.48 feet to a point;

Thence leaving said centerline and thru the lands of the grantor the following four courses;

1. South 67°24'53" East passing thru a 5/8" iron pin set at a distance of 30.00 feet and going a total distance of 441.09 feet to a 5/8" iron pin set;
2. North 60°57'29" East a distance of 270.00 feet to a 5/8" iron pin set;
3. South 29°02'31" East a distance of 400.00 feet to a 5/8" iron pin set;
4. South 00°00'00" East a distance of 200.00 feet to the principal point of beginning containing 10.3616 acres more or less subject to all legal easements and rights of way.

Bearings are assumed and are for the determination of angles only.

All iron pins set are 5/8"X30" rebar with plastic ID cap stamped "CTS-6844".

The above description was prepared from an actual survey made on the 21st day of May, 2012, by C. Thomas Smith, Ohio Professional Surveyor, No. 6844.



C. Thomas Smith

Ohio Professional Surveyor No. 6844

Description Checked for
Mathematical Accuracy
Athens County
ENGINEER'S OFFICE

BY: *S. Blausa*

DATE: *6-1-12*

BEING A PART OF THE NORTHEAST QUARTER OF SECTION 5, TOWNSHIP-10, RANGE-14, DOVER TOWNSHIP, ATHENS COUNTY, STATE OF OHIO.

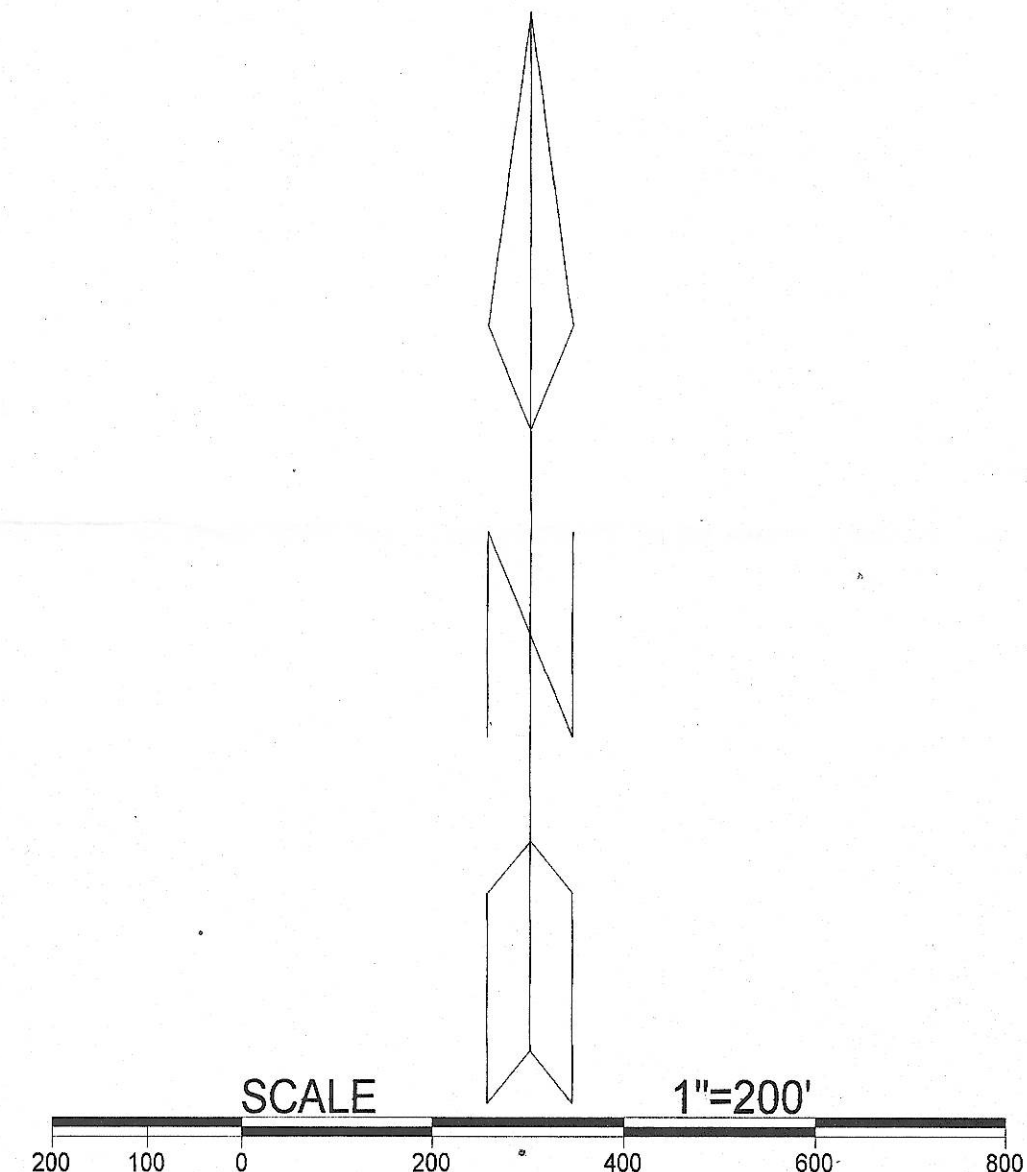
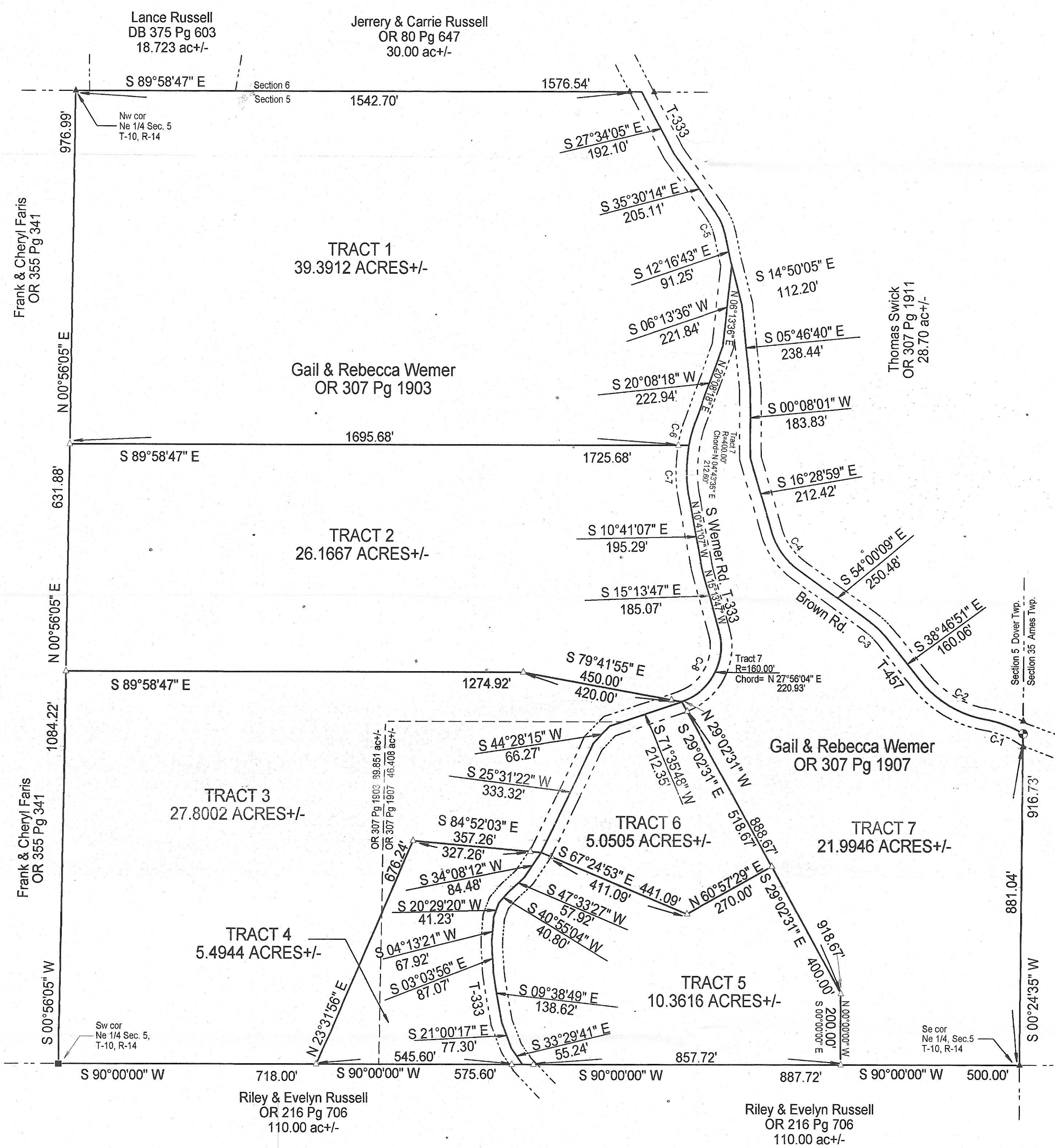

LEGEND

△	Iron pin set
▲	Iron pin found
•	Point
■	Stone (f)

REFERENCES
 Current Tax Plats
 Previous surveys
 Deeds: as noted
 Aerial Photographs
 U.S.G.S. Topo Maps

Note: Bearings are assumed and are for the determination of angles only.
 All iron pins set are 5/8"X30" rebar with plastic ID cap stamped "CTS-6844".

CURVE DATA

C-1 RADIUS=300.00'	CHORD= S 69°25'33" E	111.91'
C-2 RADIUS=300.00'	CHORD= S 59°28'42" E	212.06'
C-3 RADIUS=200.00'	CHORD= S 46°23'30" E	52.98'
C-4 RADIUS=200.00'	CHORD= S 35°14'34" E	128.64'
C-5 RADIUS=150.00'	CHORD= S 23°53'28" E	60.39'
C-6 RADIUS=400.00'	CHORD= S 15°16'28" W	67.83'
C-7 RADIUS=400.00'	CHORD= S 00°08'14" E	146.45'
C-8 RADIUS=160.00'	CHORD= S 27°56'04" W	220.93'

PLAT PREPARED FROM AN ACTUAL SURVEY MADE ON THE 21ST DAY OF MAY, 2012 BY,

 C. THOMAS SMITH OHIO PROFESSIONAL SURVEYOR No. 6844

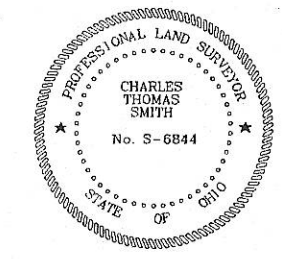

Surveyed and platted by
 C. Thomas Smith
 Ohio Professional Surveyor No 6844
 P.O. Box 393
 Racine, Ohio 45771
 740-949-2524

Description Checked for
 Mathematical Accuracy
 Athens County
 ENGINEER'S OFFICE
 BY: *S. Blawie*
 DATE: 6-1-12