



C. Thomas Smith & Associates

P.O. Box 393

Racine, Ohio 45771

740-949-2524

DESCRIPTION OF SURVEY FOR RICHARD AKERS

BEING A PART OF A TRACT OF LAND TRANSFERRED TO EARL AKERS AS RECORDED IN DEED BOOK 362 AT PAGE 415, ATHENS COUNTY RECORDER'S OFFICE, ATHENS COUNTY OHIO, ALSO BEING A PART OF SECTION 16, TOWNSHIP-10-NORTH, RANGE-15-WEST, LEE TOWNSHIP, ATHENS COUNTY, STATE OF OHIO AND MORE PARTICULARLY DESCRIBED AS FOLLOWS:

BEGINNING AT A 5/8" IRON PIN WITH I.D. CAP SET WHICH BEARS NORTH 83°39'49" EAST A DISTANCE OF 1013.83 FEET AND NORTH 05°24'48" WEST A DISTANCE OF 1050.14 FEET FROM THE ASSUMED SOUTHWEST CORNER OF SAID SECTION 16, TOWNSHIP-10, RANGE-15;

THENCE NORTH 82°58'20" EAST PASSING THRU A 5/8" IRON PIN WITH I.D. CAP SET AT A DISTANCE OF 1835.02 FEET AND GOING A TOTAL DISTANCE OF 1865.02 FEET TO A POINT IN THE CENTER LINE OF COUNTY ROAD 10, BAKER ROAD;

THENCE ALONG SAID CENTER LINE THE FOLLOWING FOUR COURSES:

1. SOUTH 29°47'32" WEST A DISTANCE OF 111.91 FEET TO A POINT;
2. SOUTH 35°08'27" WEST A DISTANCE OF 204.17 FEET TO A POINT;
3. SOUTH 34°13'48" WEST A DISTANCE OF 207.49 FEET TO A POINT;
4. SOUTH 31°37'50" WEST A DISTANCE OF 124.30 FEET TO A POINT;

THENCE LEAVING SAID CENTER LINE NORTH 86°49'58" WEST PASSING THRU A 5/8" IRON PIN WITH I.D. CAP SET AT A DISTANCE OF 30.00 FEET AND GOING A TOTAL DISTANCE OF 1671.03 FEET TO A 5/8" IRON PIN WITH I.D. CAP SET;

THENCE NORTH 37°58'44" EAST A DISTANCE OF 280.32 FEET TO THE PRINCIPAL POINT OF BEGINNING CONTAINING 15.000 ACRES± SUBJECT TO ALL LEGAL EASEMENTS AND RIGHTS-OF-WAY.

ALL IRON PINS SET ARE 5/8"X30" REBAR WITH PLASTIC I.D. CAP "CTS-6844".

BEARINGS ARE ASSUMED AND ARE FOR THE DETERMINATION OF ANGLES ONLY.

THE ABOVE DESCRIPTION WAS PREPARED FROM AN ACTUAL SURVEY MADE ON THE 18TH DAY OF APRIL , 2002, BY C. THOMAS SMITH, OHIO PROFESSIONAL SURVEYOR, #6844.

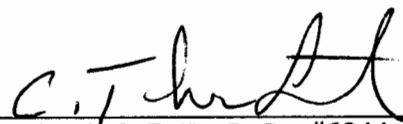
C. THOMAS SMITH, P.S. #6844

Description checked for
Mathematical Accuracy
ATHENS COUNTY
ENGINEER'S OFFICE
BY: S. Blausen
DATE: 4-25-02

54
LEE #16

BEING A PART OF SECTION 16, TOWNSHIP-10-NORTH, RANGE-15-WEST
 LEE TOWNSHIP, ATHENS COUNTY, STATE OF OHIO.

56

NOTE: BEARINGS ARE ASSUMED AND ARE FOR THE DETERMINATION OF ANGLES ONLY.

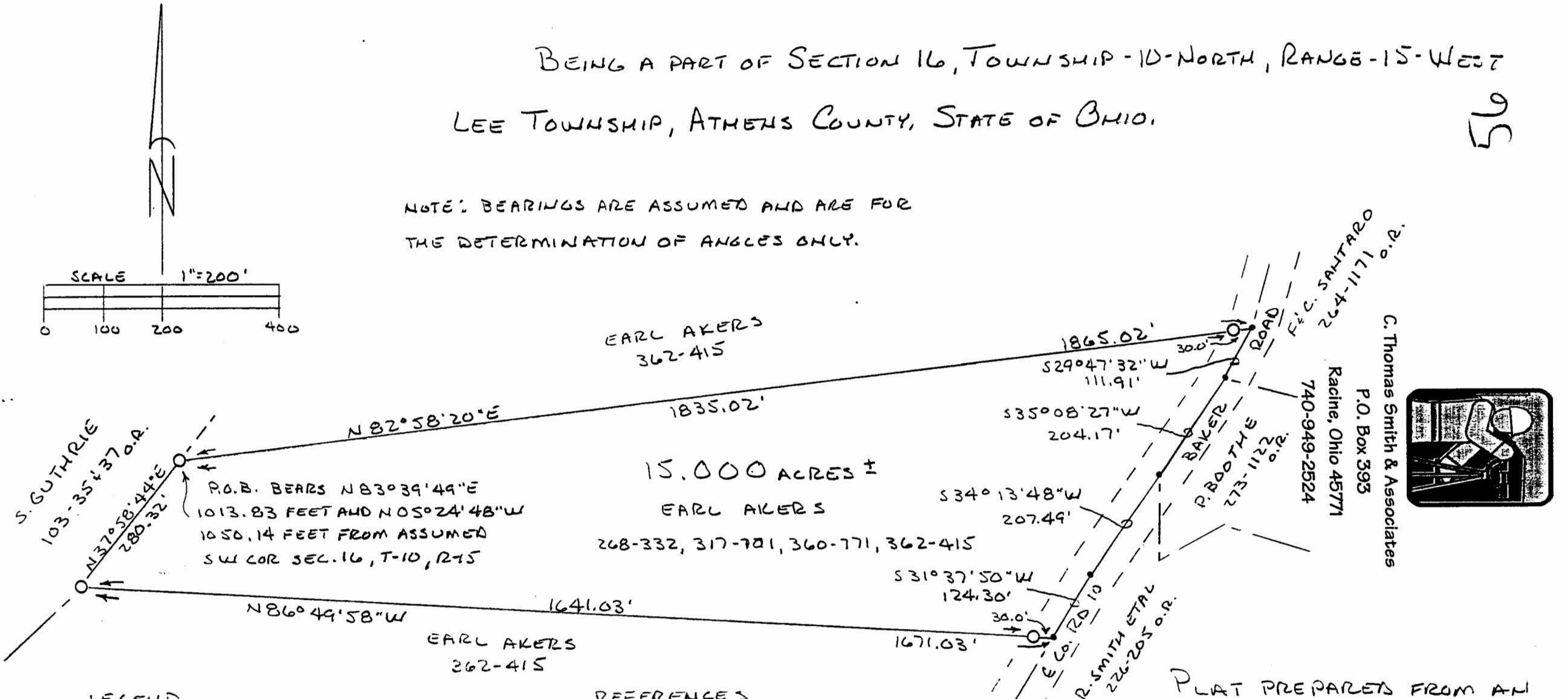
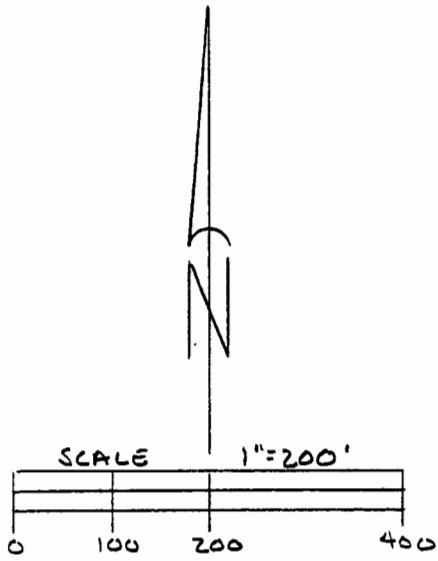

C. Thomas Smith & Associates

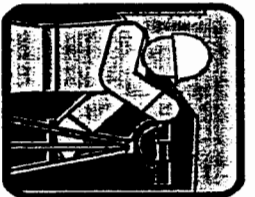

LEGEND

- - 5/8" X 30" IRON PIN WITH CAP "CTS-6844" SET
- - POINT

REFERENCES

- CURRENT TAX PLATS
- PREVIOUS SURVEYS
- DEEDS: AS NOTED

Description checked for
 Mathematical Accuracy
 ATHENS COUNTY
 ENGINEER'S OFFICE
 BY: E. Blausen
 DATE: 4-25-02

PLAT PREPARED FROM AN
 ACTUAL SURVEY MADE ON THE 18th
 DAY OF APRIL, 2002 BY,

C. Thomas Smith
 OHIO PROFESSIONAL SURVEYOR
 No. 6844